

ECOMAT PLUS



ECOMAT PLUS

Economical semi-automatic Ecomat wrapping machines are reliable, safe and easy to use.



Efficiency

- Motorized Power Pre Stretch System (260 %)
- Stepless film-tension control
- All types of power pre-stretch films can be used (i.e. Mima Films UP, BH)
- Minimum consumption of film per pallet
- Optimisation of cost per pallet

Safety

- Film carriage inside the tower
- Safe, fast and ergonomic film loading
- Control for door opening
- Emergency stop



Simplicity

- Fast and simple installation
- Safe transportation (machine packed in a wooden crate)
- Easy maintenance
- Height sensing by photocell (wrapping of black goods also possible)
- Easy film feeding – the film is just placed in the middle of the carriage and threaded through the threading slot



Easy to use

- Adjustable number of top and bottom wraps
- Adjustable carriage and turntable speed
- Support layer function
- Soft START/STOP
- Indexed stop
- 15 easily adjustable memorizable programs
- Adjustable "over the pallet" -wrapping



Options

- Access ramp
- Pit foundation template
- Load stabilizer
- Turntable diameter 2 m
- FS model

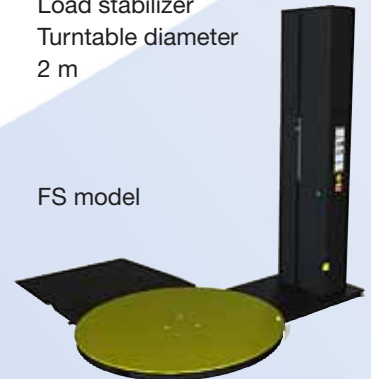

Technical data

Capacity:	15 - 25 pallets/h(depending on pallet dimensions)
Power supply:	220-240V/50Hz
Turntable speed:	2-12 rpm
Turntable height:	80 mm
Film carriage:	variable climbing speed
Machine dimensions:	2575 x 1650 mm
Turntable Ø:	1650 mm
Space required:	4.3 m2 (height 2900 mm)
Machine weight:	approx. 430 kg
Wrapping height:	2400 mm
Max. pallet weight:	2000 kg (1200 kg for FS option model)
Pallet dimensions:	L =1150 mm, W=1150 mm, H=2400 mm

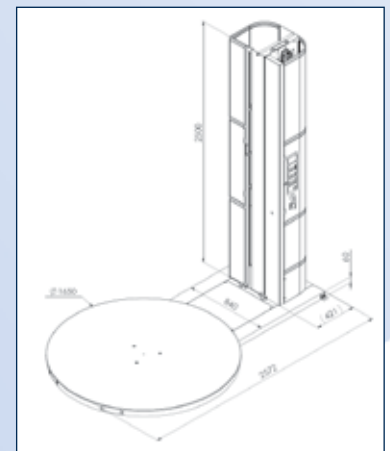

HALOILA

Machines & Service

Haloila, FI-21250 Masku (Finland), Tel.: (+358) 2 437 6111, Fax: (+358) 2 437 6211
 octopus.gb@team.haloila.com octopus.global@team.haloila.com www.haloila.com